

REMOVAL

1. REMOVE FRONT WHEEL
2. REMOVE ENGINE UNDER COVER

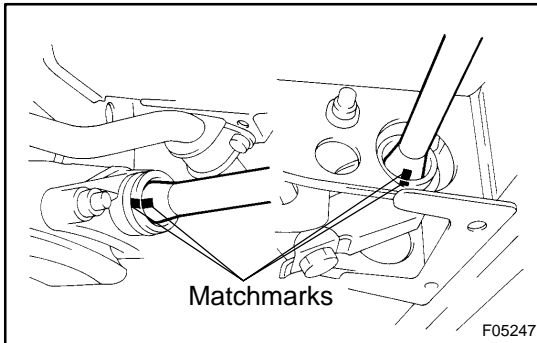

3. REMOVE TORSION BAR SPRING WITH ANCHOR ARM

- (a) Place matchmarks on the torsion bar spring, anchor arm and torque arm.

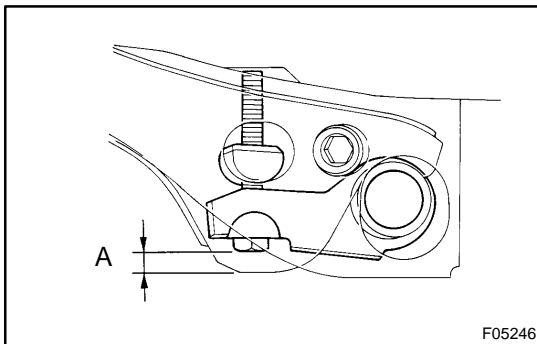

- (b) Measure the dimension "A" between the anchor arm adjusting bolt end and the frame as shown.

HINT:

Use the measurement for a reference when installing the anchor arm.

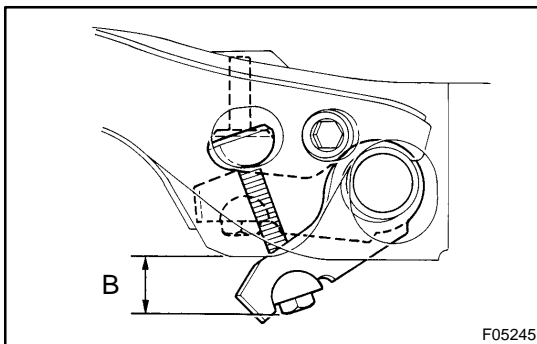

- (c) Loosen the anchor arm bolt until the spring tension is free and measure the anchor arm bolt "B".

HINT:

Use the measurement for a reference when installing the anchor arm.

- (d) Remove the anchor arm adjusting bolt, anchor arm swivel and anchor arm adjusting seat.
- (e) Remove the torsion bar spring with the anchor arm.
- (f) Remove the anchor arm from the torsion bar spring.

4. REMOVE TORQUE ARM

Remove the 2 nuts, bolt and torque arm.